

# **An Efficient method for the removal of ECG artifact from measured EEG Signal using PSO algorithm**

**S.Suja Priyadharsini<sup>1</sup> and S.Edward Rajan<sup>2</sup>**

<sup>1</sup>Assitant Professor, Department of ECE,  
Anna University:Tirunelveli Region, Tirunelveli, India  
e-mail: sujapriya\_moni@yahoo.co.in

<sup>2</sup>Professor, Department of EEE,  
Mepso Schlenk Engineering College, Sivakasi, India  
e-mail: sedraj@yahoo.com

## **Abstract**

*Electroencephagram (EEG) is the recording of electrical activity of the brain. Though it is intended to record cerebral signals, it also records the signals that are not of cerebral origin called artifacts. Artifact removal from EEG signals is essential for better diagnosis. This paper proposes a hybrid learning algorithm based on Adaptive Neuro-Fuzzy Inference System (ANFIS) for eliminating ECG artifact from EEG signal. The proposed hybrid learning algorithms, ANFIS-PSO uses Particle Swarm Optimization (PSO) algorithm for tuning the antecedent and consequent part of the ANFIS. Performance of the proposed technique is compared with ANFIS. Improvements in the output Signal-to-Noise Ratio (SNR), minimum Mean-Square Error (MSE) along with the Power Spectrum Density (PSD) plot are used as the criteria for comparing the performance of the algorithm. It is found that the proposed ANFIS-PSO algorithm works better, and outperforms the ANFIS technique in minimizing the ECG artifacts from the corrupted EEG signals.*

**Keywords:** *Electroencephalogram (EEG), Electrocardiogram (ECG), Adaptive Neuro-Fuzzy Inference System (ANFIS), Particle Swarm Optimization (PSO).*

## **1 Introduction**

EEG recordings reflect the action of the brain by recording the electrical activities of the brain. Electrical activities arising from sites other than the

brain are also recorded by EEG, though it is designed to record solely the cerebral activity. Recorded activities that did not originate from the brain are called artifacts. These artifacts may interfere with the detection and analysis of events of interest and hinder the interpretation of EEG recordings [1]. Since artifacts may cause inaccuracy or even critical errors during visually screening or computer analysis, pure EEG records without artifacts will improve the accuracy of visual inspection or computer-based analysis in the long term. [2] Automatic processing of EEG signals by computers is desirable in both clinical and experimental EEG analysis for the reasons such as to obtain precise characterization and quantification, to avoid errors due to subjectivity and to minimize the processing time. But , automated analysis of the EEG is affected by the lack of reliable means for removing artifacts, in order to distinguish artifacts and signals of cerebral origin[3]. Many techniques have been developed to extract artifact free EEG signal. Some of the techniques involve Wavelet-ICA[Independent Component Analysis] [1], adaptive filtering methods[4] etc. However, these techniques involve complex manual calculations and mostly depend on visual analysis. Joe-Air Jiang. et al, proposed an automated method for detecting and eliminating electrocardiograph (ECG) artifacts from electroencephalography (EEG) without an additional synchronous ECG channel[2]. It involves decomposition of signal to extract ECG peaks and adaptive wavelet thresholding. The wavelet bases used with algorithm avoid the problem of time shift after processing. However improper choice of bases function and decomposition level causes deterioration of signal quality. Many papers focus on removing EOG artifact present in EEG signal. P. Senthil Kumar et al. [5] have described an adaptive filtering method for eliminating the ocular artifacts from the electroencephalogram (EEG) records. For removing ocular artifacts from EEG recordings through wavelet transform, the technique in this paper uses an adaptive filtering method that utilizes RLS (Recursive Least Square) algorithm. Moreover P. Senthil Kumar et al. concluded that the adaptive cancellation with help of wavelet decomposition can be considered as a pre-processing work for enhancing the quality of EEG signals in biomedical analysis. In [6] ANFIS model is applied to remove EOG artifact and combined EOG, EMG artifacts. However the proposed technique in this paper focuses on removing ECG artifacts present in the EEG signal.

## 2 Problem Formulations

### 2.1 EEG artifacts removal using ANFIS and ANFIS tuned PSO

#### 2.1.1 Adaptive Noise Cancellation (ANC)

Adaptive algorithms play a very important role in many diverse applications such as communications, acoustics, speech, radar, sonar, seismology, and biomedical engineering [7]. The Principle used for noise cancellation in this proposed method is Adaptive Noise Cancellation (ANC). Usually linear filters are used for adaptive noise cancellation. In this paper Adaptive Noise Cancellation (ANC) based on ANFIS is used for artifact removal. The measured EEG signal from the scalp is contaminated by various artifacts such as ECG(cardiac artifacts),EOG(ocular artifacts),EMG(muscular artifacts) and glossokinetic artifacts. Hence the removal of artifacts is essential for effective diagnosis. This paper focuses on ECG artifact removal . The measured EEG signal is the super position of original EEG signal due to brain activity and the fraction of ECG signal due to heart activity.

$$EEG_M(t) = EEG_O(t) + ECG_N(t) \quad (1)$$

where

$EEG_M(t)$ -Measured EEG signal.

$EEG_O(t)$ -Original EEG signal due to brain activity.

$ECG_N(t)$ -Non linearly transformed ECG signal due to the propagation of ECG signal from heart to the measuring location.

The aim of the proposed scheme is to extract required EEG signal  $EEG_O(t)$  from the measured signal  $EEG_M(t)$  which consists of the required signal  $EEG_O(t)$ , plus the interference signal  $ECG_N(t)$  i.e., the distorted and delayed version of ECG(t). In this paper ,  $EEG_M(t)$  is used as the primary input and ECG signal is used as the reference input to estimate ECG artifact signal  $ECG_N(t)$  present in measured EEG signal.

The performance of the proposed technique is evaluated for three sets of data's. First as well as second set of data uses simulated artifact signal mixed with EEG signal to generate EEG signal with artifact. Third data set is a real polysomnograph EEG recording with ECG artifacts. To generate the artifact signal  $ECG_N(t)$  for first two data sets ,the ECG signal is delayed twice and transformed using nonlinear function. In this paper , the nonlinear function is modelled as a sigmoidal function, based on the transfer function of biological

neuron [8].

The basic concept in this paper is to estimate the unknown interference  $ECG_N(t)$  present in the measured EEG signal and to subtract it from the measured EEG signal,  $EEG_M(t)$ .

$$\hat{EEG}_O(t) = EEG_O(t) + ECG_N(t) - \hat{ECG}_N(t), \quad (2)$$

where

$\hat{EEG}_O(t)$ -Estimated EEG signal

In this proposed research work ,the unknown interference present with the desired EEG signal, is estimated using ANFIS, and ANFIS-PSO techniques and the results obtained are analysed. ANFIS-PSO technique is used to estimate the unknown interference, for enhancing the quality of estimated EEG signal more than that of ANFIS.

### 2.1.2 Adaptive Neuro-Fuzzy Inference System (ANFIS)

ANFIS is a network which combines the advantages of neural network and fuzzy system [9].ANFIS is an adaptive network functionally equivalent to fuzzy inference system(FIS).The adaptive network learn a relationship between inputs and outputs.The ANFIS is composed of two parts,viz. the antecedent and consequent part. These are connected to each other by the fuzzy rules in network form.

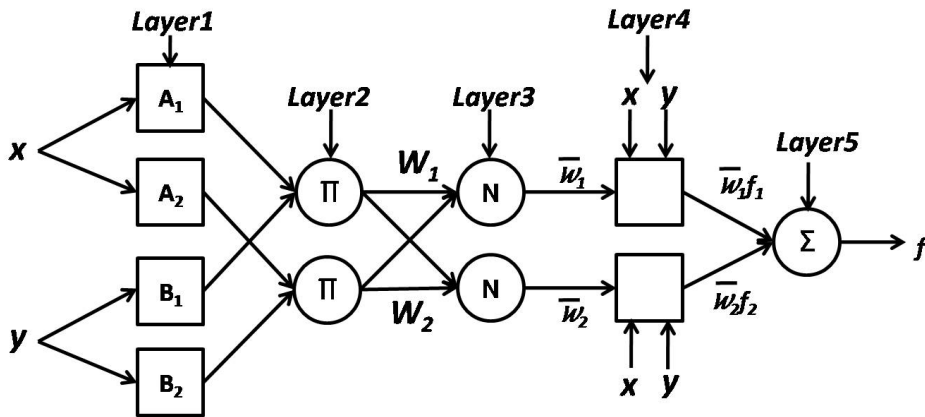

Figure 1: ANFIS architecture

The ANFIS architecture shown in Fig.1 is a five layer network.Two fuzzy if-then rules based on a first order Sugeno model are considered:

$$\text{Rule1 : If}(x \text{ is } A_1) \text{ and } (y \text{ is } B_1) \text{ then } (f_1 = p_1x + q_1y + r_1) \quad (3)$$

$$\text{Rule2 : If}(x \text{ is } A_2) \text{ and } (y \text{ is } B_2) \text{ then } (f_2 = p_2x + q_2y + r_2) \quad (4)$$

where  $x$  and  $y$  are the inputs,  $A_i$  and  $B_i$  are the fuzzy sets,  $f_i$  are the outputs within the fuzzy region specified by the fuzzy rule,  $p_i, q_i, r_i$  are the consequent parameters that are determined during the training process. The function of node in each layer are as follows:

Layer 1: In this layer, the membership grades of a linguistic label are generated by each node. The output of each node is

$$O_i^1 = \mu_{A_i}(x) = \frac{1}{1 + \left| \frac{x-c_i}{a_i} \right|^{2b_i}}, \quad (5)$$

where  $x$  is the input to node  $i$ ;  $A_i$  is the linguistic label (very low, low, medium, large, very large etc) of the  $i_{th}$  node; and  $a_i, b_i, c_i$  is the parameter set that alters the shapes of the membership function. Parameters of this layer are called premise parameters.

Layer 2: Every node in this layer is fixed. The firing strength of a rule is calculated by each node of this layer through multiplication

$$O_i^2 = W_i = \mu_{A_i}(x)\mu_{B_i}(y), \quad i = 1, 2 \quad (6)$$

Layer 3: Layer 3 contains fixed nodes which calculates the ratio of the firing strengths of the rules

$$O_i^3 = \overline{W}_i = \frac{W_i}{W_1 + W_2}, \quad i = 1, 2 \quad (7)$$

Layer 4: The nodes in this layer are adaptive and perform the consequent of the rules

$$O_i^4 = \overline{W}_i f_i = \overline{W}_i (p_i x + q_i y + r_i), \quad i = 1, 2, \quad (8)$$

where  $W_i$  and  $p_i, q_i, r_i$  are the output of layer 3 and the parameter set respectively. Parameters of this layer are to be determined and are called as consequent parameters

Layer 5: The single node of this layer computes the overall output:

$$O_i^5 = \text{overall output} = \sum \overline{W}_i f_i = \frac{\sum \overline{W}_i f_i}{\sum \overline{W}_i}, \quad i = 1, 2 \quad (9)$$

From the ANFIS architecture shown in Fig.1, it is obvious that a linear combination of the consequent parameters can be used to represent the overall output  $f$ , provided the values of premise parameters are known[10] [11].

$$f = \overline{W}_1 f_1 + \overline{W}_2 f_2 = (\overline{W}_1 x) p_1 + (\overline{W}_1 y) q_1 + (\overline{W}_1) r_1 + (\overline{W}_2 x) p_2 + (\overline{W}_2 y) q_2 + (\overline{W}_2) r_2 \quad (10)$$

The ANFIS uses a gradient descent algorithm to optimize the antecedent parameters and a least square algorithm to solve the consequent parameters. Because it uses two different algorithms to reduce the error, the training rule is called a hybrid[12]. The performance of ANFIS mainly depends on the appropriate choice of membership functions of the linguistic labels set[13]. In this proposed work, ANFIS architecture is implemented using equations (5) to (10) and the FIS parameters are tuned by using the generalized bell type as the membership function (MF). ANFIS estimates the unknown interference that exists in the measured signal using hybrid-learning algorithm.

### 2.1.3 Particle Swarm Optimization (PSO)

The PSO algorithm is based on the biological and sociological behaviour of birds searching for their food [14]. PSO gives better results in a faster way when compared with other optimization methods[15]. Let us consider an optimization problem of ' $k$ ' variables and PSO is initialized with  $N$  number of random particles (solutions) and each particle is assigned a random position in the ' $k$ ' dimensional space. PSO searches for optima by updating generations. In each iteration, each particle is updated by two "best" values. The first one is the best position (fitness) the particle has achieved so far. This value is called *pbest*. Another "best" value that is tracked by the particle swarm optimizer is the best value, obtained so far by any particle in the population. This best value is a global best and called *gbest*. The PSO algorithm is summarised as follows

Step 1: Initialize  $N(i)$  particles each with dimension ' $k$ ' randomly. Set the values for  $c_1, c_2, w, r_1,$  and  $r_2$ .

Step 2: Initialize position ' $S_k(i)$ ' and velocity ' $V_k(i)$ ' randomly.

Step 3: Calculate fitness  $F$  ( mean square error value ) for each particle.

Step 4: For each iteration select particles best value (*pbest*) by comparing the

performance of each particles to its best performance. If  $F(S_k(i)) < pbest$  then  $pbest_k = F(S_k(i)); S_{pbest_k} = S_k(i)$

Step 5: Select particle with best fitness (minimum mean square error) among all particles as  $gbest$ . If  $F(S_k(i)) < gbest$  then  $gbest = F(S_k(i)), S_{gbest} = S_k(i)$

Step 6: Update new velocity and new position of the particle by using  $pbest$  and  $gbest$  values in the following equations.

$$V_k(i) = wV_k(i-1) + c_1r_1(S_{pbest_k} - S_k(i)) + c_2r_2(S_{gbest} - S_k(i)) \quad (11)$$

$$S_k(i) = S_k(i-1) + V_k(i) \quad (12)$$

$$i = i + 1, \quad (13)$$

where  $w$  is the inertia weight,  $c_1, c_2$  are acceleration constants both set equal to or less than 2.0 and  $r_1, r_2$  are random numbers.

Step 6: Steps 3 to 6 is repeated until stopping criteria (maximum iterations set) [9],[16],[17]. The above process is explained as a flow diagram in Fig.2.

#### 2.1.4 Hybrid Approach

This section describes the method by which PSO updates the ANFIS parameters. The PSO algorithm is used to train the parameters of membership functions in ANFIS as in [14],[15]. The membership functions used are generalized bell (gbell) function as in the equation 5. and their parameters are  $a_i, b_i, c_i$  where  $a_i$  is variance of the membership function,  $b_i$  is the trainable parameters,  $c_i$  is the centre of the membership functions. The parameters of the consequent part are  $p_i, q_i, r_i$ , which are initialized randomly.

The algorithm used for the proposed approach is described step by step as follows:

Step 1: Contaminated EEG signal is used as the target signal, the reference signal (ECG) and delayed reference signal are taken as the input data for ANFIS model.

Step 2: The parameters of antecedent and consequent part are initialized randomly. Three trainable parameters  $a_i, b_i, c_i$  are used to define Gbell MF, and if M number of membership function is used for each input then number of antecedent parameters are equal to  $(M \times 3) \times N$ , where N is the number of inputs. Here the consequent parameters are also trained by the optimization algorithm. It consists of  $(N+1)P$  number of particles, where P is the number of rules and

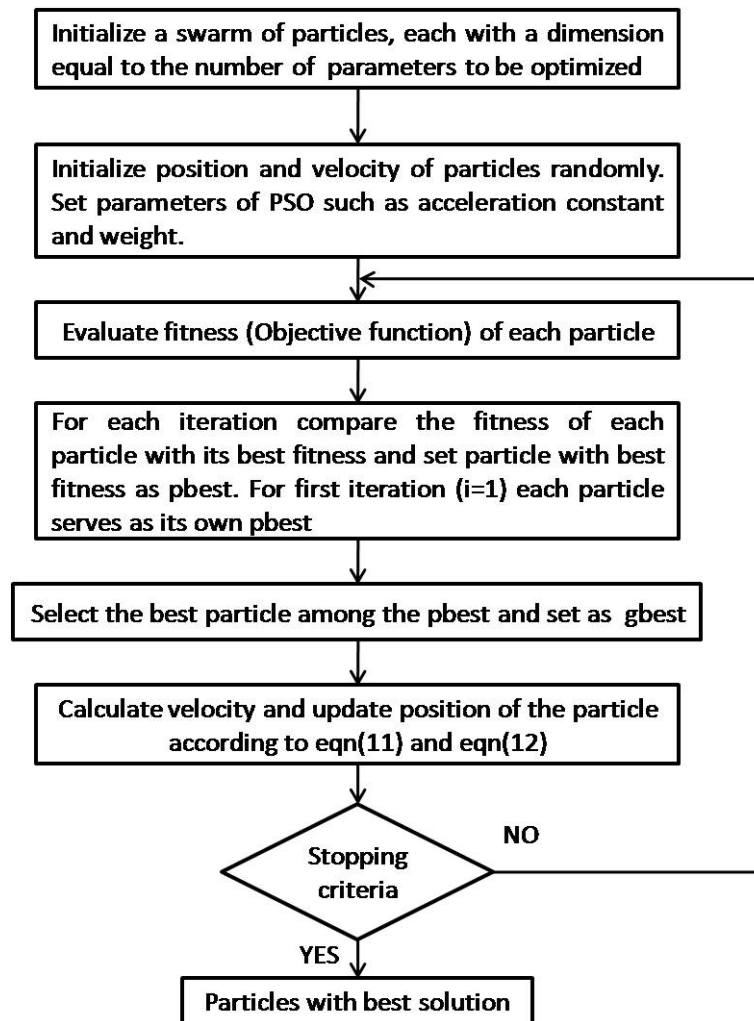

Figure 2: Flow Diagram of PSO

N is the number of input data [18]. From the input data, antecedent and consequent parameters, the membership functions and rules of ANFIS are formed.

Step 3: Parameters of the membership functions are trained using PSO algorithm and the optimized parameters are submitted to the ANFIS structure. The stopping criteria used here is the maximum number of iterations. The fitness function used here is the mean square error. At the end of the maximum number of iteration, the particles with minimum mean square error are considered as the best solution and submitted to the ANFIS structure.

Step 4: Output of the ANFIS, whose parameters are optimized by PSO is extracted.



Step 5: Output obtained from ANFIS is the estimated artifact present in the contaminated EEG signal, which is subtracted from the(target) contaminated EEG signal to obtain artifact minimized EEG signal. Table 1 shows the parameter values used for PSO algorithm. The above process is explained using the flow diagram in Fig.3.

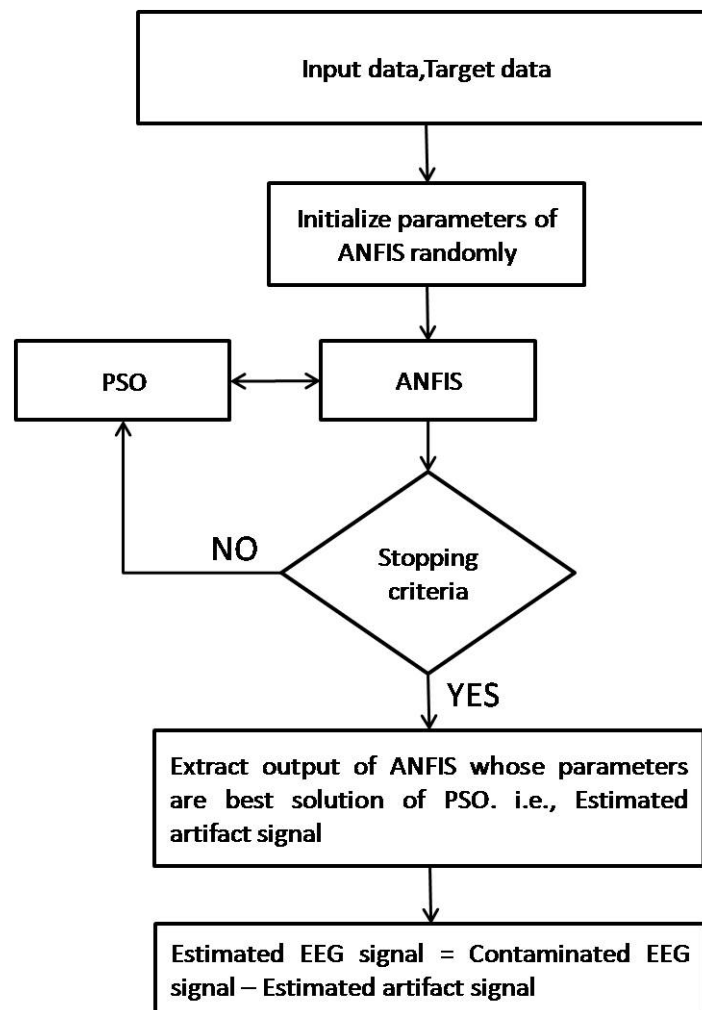

Figure 3: Flow Diagram of ANFIS-PSO

Table 1: Parameters Of PSO

Parameters	Value
No. of particles	50
No. of membership functions for each input	2
Cognitive ( $c_1$ ) and Social( $c_2$ ) acceleration	2
Inertia weight ( $w$ )	0.8
No. of iterations	60

### 3 Result and Discussion

#### 3.1 Simulation Results

In this section, the results of cardiac artifact (ECG) removal from EEG signal using ANFIS-PSO and ANFIS are discussed and their performances are compared with each other. The performance is evaluated for two sets of data. For the first and second sets of data, the EEG signal is taken from the database available in the website <http://www.physionet.org/pn6/chbmit/> and the sample ECG signals are taken from MIT arrhythmia data base of <http://www.physionet.org> for first data set and from <ftp://ftp.ieee.org/uploads/press/rangayyan/> for second data set. Before applying the techniques ANFIS and ANFIS-PSO, the signals are normalised about its mean value. Tables 2 and 3 show the experimental settings used for implementing ANFIS and ANFIS-PSO for simulated and real data sets.

Table 2: Experimental Settings of ANFIS.

Parameters	Value
Number of nodes	21
Number of linear parameters	12
Number of nonlinear parameters	12
Total number of parameters	24
Number of fuzzy rules	4
Training Method	Hybrid
Type of input MF	Gbellmf
Type of output MF	Linear

Table 3: Experimental Settings of ANFIS-PSO.

Parameters	Value
Number of nodes	21
Number of linear parameters	12
Number of nonlinear parameters	12
Total number of parameters	24
Number of fuzzy rules	4
Training Method	PSO Algorithm
Type of input MF	Gbellmf
Type of output MF	Linear

The Fig.4 and Fig.5 shows the results of the data set 1 and 2, which compares Standard EEG signal, ECG signal, Non linearly transformed ECG (artifact) signal, Standard EEG signal mixed with artifact signal and reconstructed EEG using ANFIS-PSO and ANFIS for data set 1 and 2.

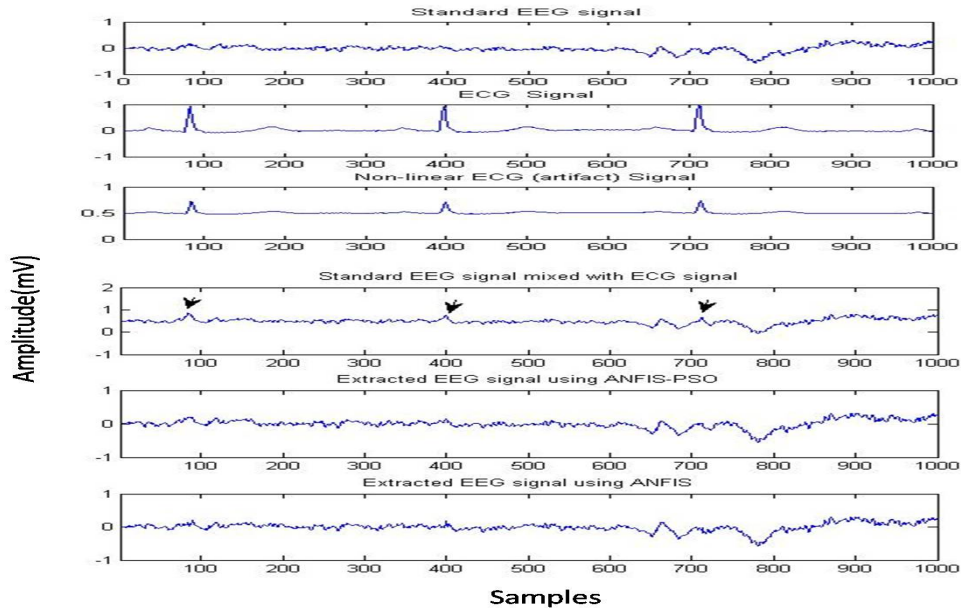

Figure 4: Comparison of ANFIS-PSO and ANFIS techniques applied to remove ECG artifact of data set 1

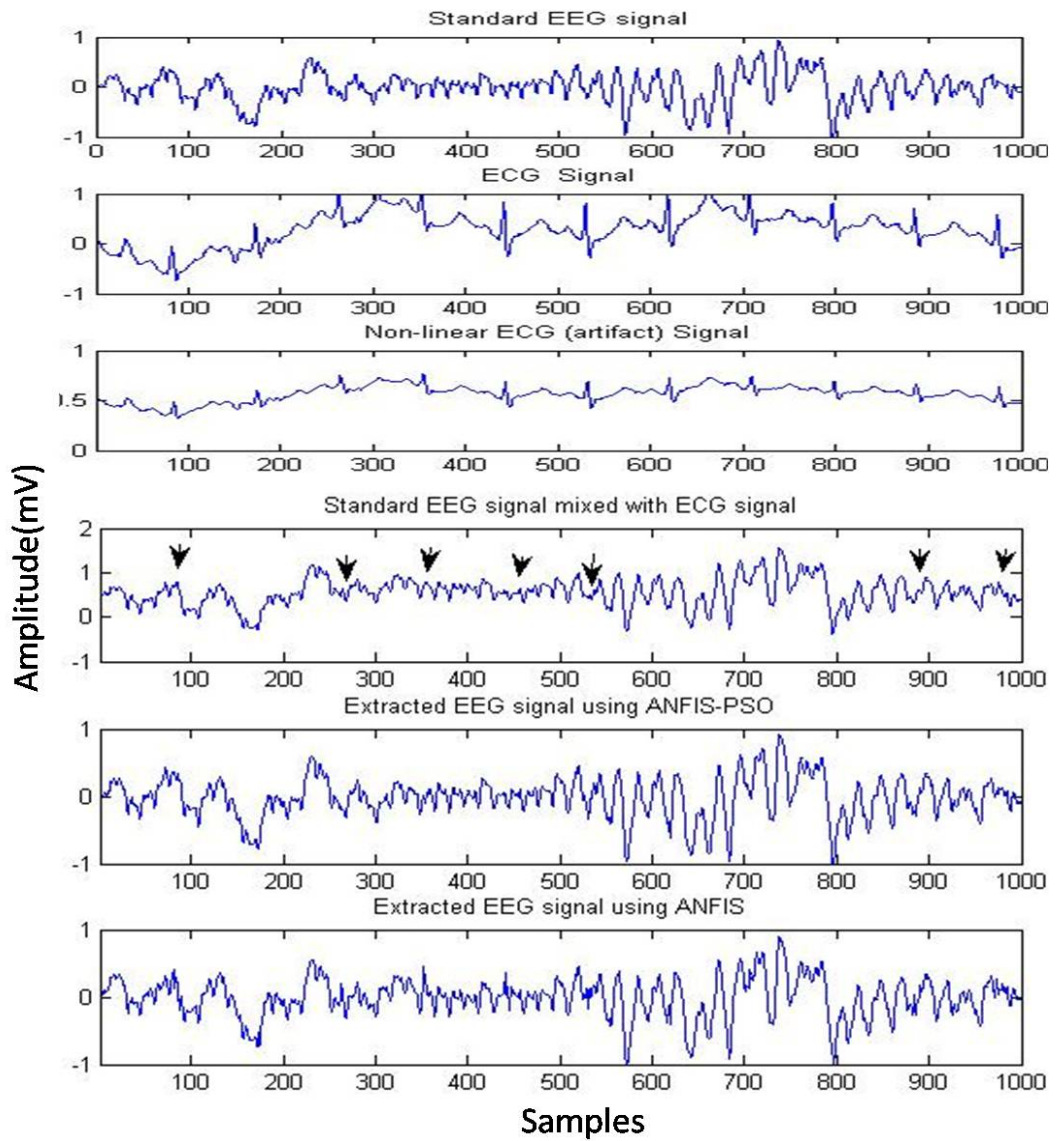

Figure 5: Comparison of ANFIS-PSO and ANFIS techniques applied to remove ECG artifact of data set 2

Fig.6 and Fig.7 shows the Standard EEG signal overlapped with reconstructed EEG signal obtained by applying ANFIS-PSO and ANFIS for data set 1 and 2. It clearly illustrates that ANFIS-PSO outperforms the ANFIS technique.

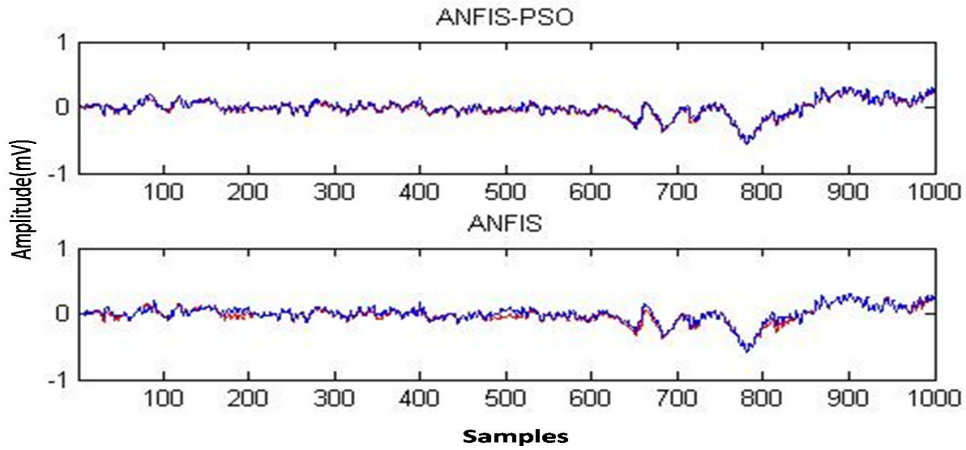

Figure 6: A typical correction of EEG signal by ANFIS and ANFIS-PSO for dataset 1 : Standard EEG (red line) and corrected EEG (blue line).

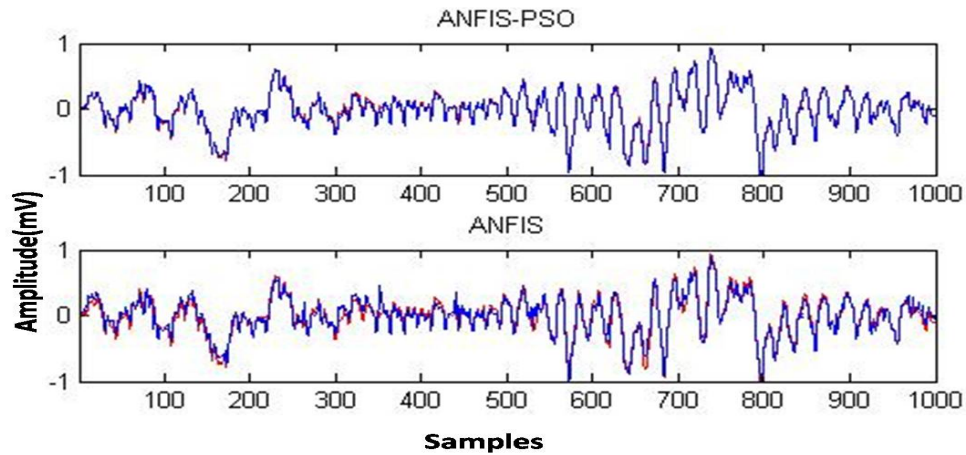

Figure 7: A typical correction of EEG signal by ANFIS and ANFIS-PSO for dataset 2 : Standard EEG (red line) and corrected EEG (blue line).

Fig.8 and Fig.9 show the Power Spectrum Density (PSD) plots, which is used to determine the frequency components present in the signal. It is used to determine the propinquity of the extracted signal towards the standard signal. The following figures show the PSD plot of the standard EEG signal, extracted EEG signal through two different techniques namely ANFIS-PSO and ANFIS.

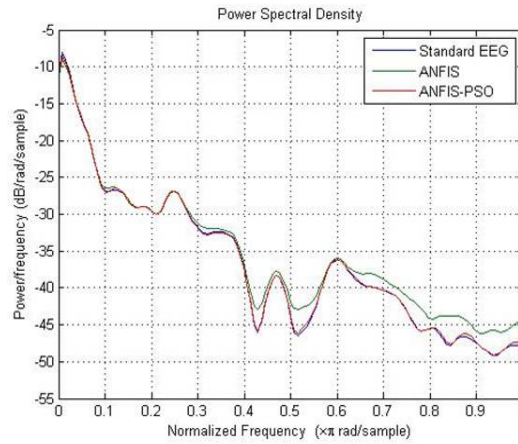

Figure 8: PSD plots of data set 1.

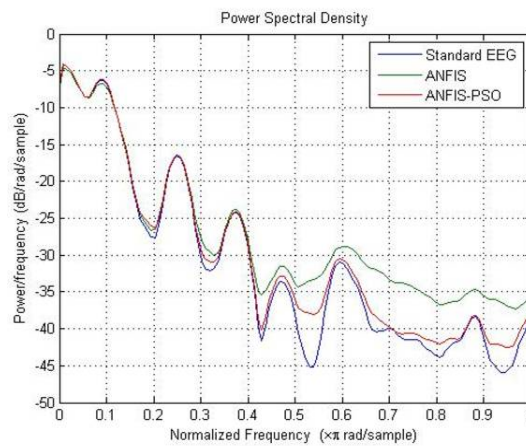

Figure 9: PSD plots of data set 2.

From the above PSD plots, it is evident that the power of the spectral component of the reconstructed EEG signal has been retained since the PSD plot of reconstructed EEG signal obtained by applying ANFIS PSO technique is much closer with the PSD plot of the standard EEG signal. Hence ANFIS-PSO technique extracts EEG signal better than ANFIS.

## Performance Analysis

In order to compare the performance of the artifact removal, output Signal to Noise Ratio (OSNR) and Mean Square Error (MSE) are calculated. The Output SNR(OSNR) is calculated using the following formula:

$$OSNR = 10 \log_{10} \left( \frac{\sum (\hat{EEG}_o)^2}{\sum (EEG_o - \hat{EEG}_o)^2} \right) \quad (14)$$

Where  $\hat{EEG}_o$  is the estimated EEG signal.  $EEG_o$  is the original EEG signal. MSE is calculated using the following formula

$$MSE = \frac{\sum (error)^2}{length(error)} \quad (15)$$

where,  $error = EEG_o - \hat{EEG}_o$

In this paper, performance of the ANFIS is improved by optimizing its parameters using Particle Swarm Optimization Algorithm and the results of which are tabulated in Table 4 respectively.

Table 4: Performance comparison of ANFIS-PSO and ANFIS

Methods	Data set 1			Data set 2		
	Input SNR (dB)	SNR (dB)	MSE	Input SNR (dB)	SNR (dB)	MSE
ANFIS-PSO	0.0781	15.0245	5.1424e-004	1.0294	21.8553	5.8904e-004
ANFIS	0.0781	10.0423	0.0015	1.0294	11.9711	0.0054

On comparing the above two techniques, SNR value is high and the MSE value is low for ANFIS-PSO than ANFIS . Hence the hybrid approach of tuning ANFIS parameters using PSO outperforms the ANFIS technique. It is evident from the above simulation results that the proposed hybrid approach, ANFIS-PSO yields the better result and outperforms ANFIS. It improves the performance of ANFIS.

### 3.2 Real data result

From the simulation it is evident that ANFIS-PSO performs well than ANFIS. Hence in this section cardiac artifact removal in real data is demonstrated using ANFIS-PSO technique. The MIT-BIH Polysomnographic Database is a collection of recordings of multiple physiologic signals during sleep. Subjects were monitored in Boston's Beth Israel Hospital Sleep Laboratory . The database contains over 80 hours' worth of four-, six-, and seven-channel polysomnographic recordings, each with an ECG signal annotated beat-by-beat, and



EEG and respiration signals annotated with respect to sleep stages and apnea [19]. Database of EEG with ECG artifact is considered (slp32) [20], and artifact removal is carried out using ANFIS-PSO. Finally removed signal is low pass filtered to remove line interference. The following figure shows the comparison of reference ECG signal, corrupted EEG signal, extracted EEG signal after removing ECG artifact and low pass filtered signal

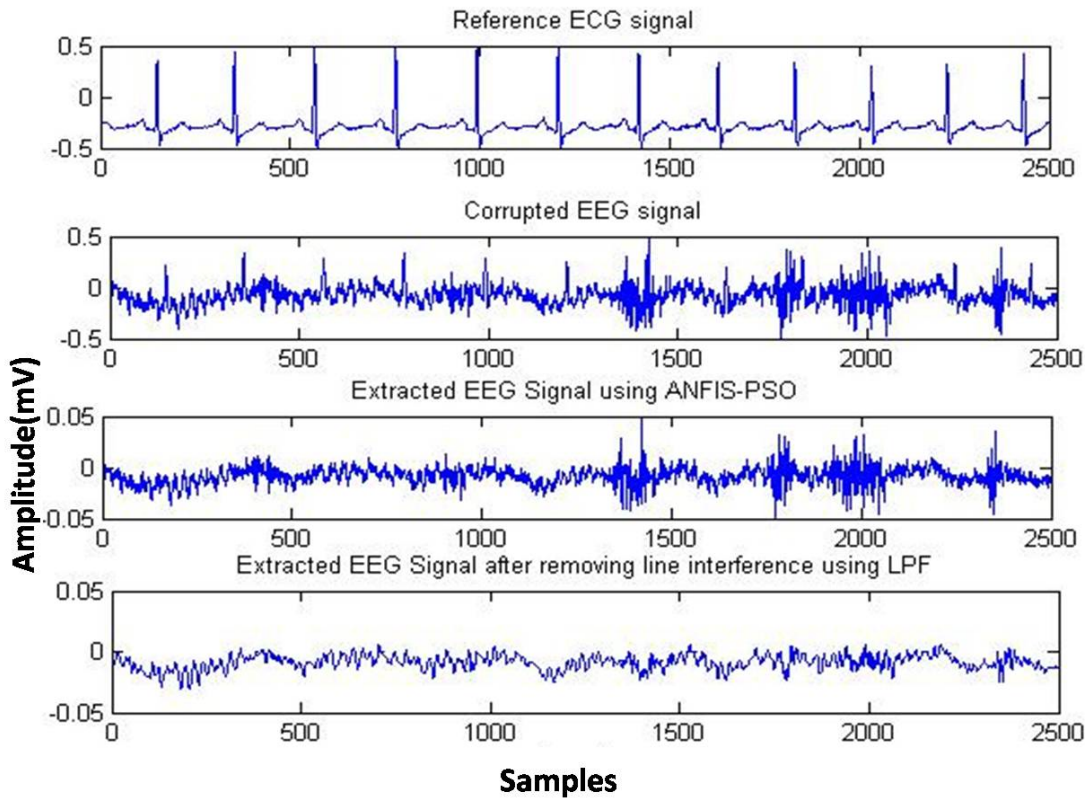

Figure 10: Real Polysomnograph data. (a) ECG signal (b) Corrupted EEG signal with ECG artifact (c) Extracted EEG signal after ECG artifact removal using ANFIS-PSO (d) Extracted EEG signal after line interference removal using low pass filter.

## 4 Conclusion

Electroencephalography (EEG) is contaminated by various artifacts, out of which ECG is one of the main sources of artifacts that affects the electroencephalographic (EEG) data. Therefore, effective minimization of artifacts from the collected data is important for preparing the data for further clinical analysis. In this paper, we exhibit the use of the proposed adaptive algorithm



,ANFIS- PSO for the minimization of ECG artifacts from the contaminated EEG signals. The proposed algorithm is compared with Adaptive Neuro-Fuzzy Inference System (ANFIS) to evaluate its relative performance. We have evaluated the performance of the algorithm using simulated signals . Output SNR improvement , minimum MSE and PSD plot are used as the performance measures for comparison. Results obtained shows that ANFIS-PSO technique outperforms the ANFIS technique, and also it is evident that the performance of ANFIS can be improved by tuning its antecedent and consequent parameters with optimization techniques such as PSO. Hence the algorithm ANFIS-PSO is applied to real polysomnograph EEG data with ECG artifact and it is evident from the result that ANFIS-PSO performs well in removing EEG artifact from EEG.

## 5 Open Problem

This research will be continued to eliminate combined artifacts such as EOG (Electrooculogram) and ECG(Electrocardiogram) in real time signals.

## References

- [1] Hosna Ghandeharion ,Abbas Erfanian. 2010. A fully automatic ocular artifact suppression from EEG data using higher order statistics:Improved performance by wavelet analysis, *Medical Engineering and Physics*, Vol.32, pp.720–729.
- [2] Joe-Air Jiang,Chih-Feng Chao,Ming-jang Chiu,Ren-GueyLee,Chwan-Lu Ch Tseng,Robert Lin. 2007. An Automatic analysis method for detecting and eliminating ECG artifacts in EEG. *Computers in Biology and Medicine*,Vol.3,pp.1660–1671.
- [3] Puthusserypady.S ,Ratnarajah.T. 2006. Robust adaptive techniques for minimization of EOG artifacts from EEG signals, *Signal Processing*, Vol.86, pp.2351–2363.
- [4] Suresh. H. N and Puttamadappa.C.2008.Removal of EMG and ECG artifacts from EEG based on real time recurrent learning algorithm, *International Journal of Physical Sciences*, Vol. 3, No.5, pp. 120–125
- [5] Senthil Kumar.P, Arumuganathan.R, Sivakumar.K and Vimal.C. 2009. An adaptive method to remove ocular artifacts from EEG signals using Wavelet Transform, *Journal of Applied Sciences Research*, Vol.5,No.7,pp 741–745.

- [6] Suja Priyadharsini. S and Edward Rajan.S. 2012. An efficient soft-computing technique for extraction of EEG signal from tainted EEG signal, *Applied Soft Computing*, Vol.12, pp.1131-1137.
- [7] Widrow, B. and S.D. Stearns. 1985. *Adaptive Signal Processing*, Prentice Hall.
- [8] P. K. Sadasivan and D. Narayma Dutt. 1994. A non-linear estimation model for adaptive minimization of EOG artifacts from EEG signals, *International Journal of Biomedical Computing*, Vol.36,No.3 pp.199–207.
- [9] Mahdi Aliyari Shoorehdeli, Mohammad Teshnehlab, AliKhaki Sedigh. 2009. Training ANFIS as an identifier with intelligent hybrid stable learning algorithm based on particle swarm optimization and extended Kalman filter, *Fuzzy Sets and System*, Vol.160 ,pp. 922-948 .
- [10] Jang, J.-S.R. 1996. Input selection for ANFIS learning, *Proceedings of the Fifth IEEE International Conference on Fuzzy Systems*, Vol. 2, pp. 1493.
- [11] J.-S.R.Jang. 1993.ANFIS:Adaptive-network-based fuzzy inference system, *IEEE Transaction on Systems Man and Cybernetics*, Vol. 23, No. 3, pp. 665-685.
- [12] Wesley Hines, J. 1997. *Fuzzy and Neural Approaches in Engineering MATLAB Supplement* John Wiley and Sons.
- [13] Pejman Tahmasebi and Ardeshir Hezarkhani. 2010. Application of Adaptive Neuro-Fuzzy Inference System for Grade Estimation, *Australian Journal of Basic and Applied Sciences*, Vol.4,No.3 pp.408–420.
- [14] J. P. S. Catalao, H. M. I. Pousinho. 2011. Hybrid Wavelet-PSO-ANFIS approach for Short-term Wind power forecasting in Portugal, *IEEE Transaction on Sustainable Energy*, Vol.2,No.1 pp.50–59.
- [15] Rini P.D, Shamsuddin M.S., and Yuhaniz S.S. 2013. Balanced the trade-offs problem of ANFIS using particle swarm optimisation, *AWERProcedia Information Technology and Computer Science*, vol.4,pp 186–193.
- [16] J. Kennedy and R.C.Eberhart. 1995. Particle swarm optimization, *Proceedings of IEEE International Conference on Neural Networks*, Vol.4, pp.1942-1948.
- [17] Eberhart, R. C., and Kennedy, J. 1995. A new optimizer using particle swarm theory, *Proceedings of the Sixth International Symposium on Micro Machine and Human Science*, Nagoya, pp.3943.

- [18] V.Seydi Ghomsheh , M. Aliyari Shoorehdeli ,M. Teshnehlab . 2007. Training ANFIS Structure with Modified PSO Algorithm, *Proceedings of Mediterranean conferences on Control and Automation*,Athens-Greece.
- [19] Goldberger AL, Amaral LAN, Glass L, Hausdorff JM, Ivanov PCh, Mark RG, Mietus JE, Moody GB, Peng C-K, Stanley HE. 2000. PhysioBank, PhysioToolkit, and PhysioNet: Components of a New Research Resource for Complex Physiologic Signals, *Circulation* 101(23):e215-e220 [*Circulation Electronic Pages*; <http://circ.ahajournals.org/cgi/content/full/101/23/e215>].
- [20] [www.physionet.org](http://www.physionet.org)